

# The Excavation Technology used in the Cow Catacombs of the Sacred Animal Necropolis, North Saqqara, Egypt

**Christopher J. Davey**

**Abstract:** The technology used in tomb excavation in ancient Egypt has not been the subject of thorough investigation to date. A 'false end' in the catacombs of the mother of Apis bulls at the North Saqqara necropolis provides evidence of one excavation system used by tomb excavators. Chisel marks and 'cone' excavations elsewhere in the catacombs provide some evidence of an alternative practice. The paper interprets this evidence and shows that practices used in ancient Egypt in principle at least are still applied today, albeit in conjunction with explosives. It is noteworthy that the main chisel types used in the construction of the Cow Catacombs have not been discovered in archaeological excavation in Egypt.

The excavations of the Sacred Animal Necropolis at North Saqqara Egypt have previously been reported in *Buried History* (Anon 1979). That article was largely based on Professor John Ray's earlier paper entitled 'The World of North Saqqara' (1978). Ray described how the Egypt Exploration Society (EES) conducted excavations in the necropolis from 1964 under the direction of Professor W.B. Emery, and how after his death in 1971 Professors Geoffrey T. Martin and Harry S. Smith continued the work until 1976. Two volumes of excavation reports have been published by the EES to date and others are in preparation (Martin 1981; Green 1987).

This paper is published with the kind approval of the Egypt Exploration Society, Dr Paul Nicholson and Professor Emeritus Harry Smith. The fieldwork described herein was carried out with Professor Smith's facilitation and his helpful comments on the publication of it are gratefully acknowledged, as are those of Professor John Tait.

The necropolis at North Saqqara is located near the village of Abu Sir on the south side of a shallow valley that runs westward from Abu Sir to the Serapeum. In summary the EES excavations at the necropolis discovered a complex of terraced temples, and a number of subterranean galleries or catacombs containing four million mummified ibises, half a million falcons, and the burial places for five hundred mummified baboons and a score of sacred cows. Other objects included about four thousand dedicatory statues, about one thousand documents in Demotic, Greek, Aramaic, Coptic, Carian and Arabic.

The complex was associated with the cult of the Apis bull whose burial place was in the Serapeum. A road led from

the Serapeum along the valley to a lake in front of the terraced temple complex at North Saqqara. The complex was a place of pilgrimage from the fourth century BCE onward for people in the eastern Mediterranean. Economic development occurred in the immediate area to satisfy the requirements of pilgrims, but nothing has been found of the hostels, shops and manufacturing facilities.

Included in the North Saqqara complex were catacombs where the mother of the Apis bull was buried. The catacombs were cleared during Professor Emery's last season at Saqqara in 1969/1970 and were described in a preliminary report (Emery 1971). These catacombs will be referred to as the Cow Catacombs and are generally known for a series of small limestone stelae written in Demotic on behalf of the workmen who supervised each burial, some of whose work is the subject of this paper.

The author was a member of the 1976 temple-town survey team at North Saqqara led by Professor Harry Smith and in addition to the function of surveying and drafting spent some afternoons studying the Catacombs for the mothers of Apis (Smith & Jeffreys 1978). In the catacombs there is evidence for the excavation technology and systems used by the workmen. A preliminary publication of the investigation results was published in *Der Anschnitt*. (Davey 1980)

## **Excavation technology in Ancient Egypt**

Egyptian monuments display prodigious amounts of stone masonry and Egypt's countless tombs were formed from many kilometres of excavation and so it is understandable that there has been an interest in Egypt's workmen. The



**Figure 1:** A plan of the Cow Catacombs showing the areas of fall and sand, and the location of the false end.

discovery of workmen's villages at Kahun, Deir el Medina and El Amarna has provided much of the evidence for that study. Many tools have been found in these excavations, some of which were published by Petrie in his *Tools and Weapons* chapter IX, 'Builders Tools' (1917:41-43). The operating systems of the workmen who excavated the tombs of Egypt have been partially revealed by the texts of the community at Deir el Medina, but the technical details of their work procedures 'at the face' have remained largely obscure (Romer 1984:14-18, 82-87).

An early discussion of quarrying and stone working is found in Lucas' *Ancient Egyptian Materials and Industries* (1964:63-74). John Weeks provided some basic illustrations that give an indication of the strategies adopted for quarrying, but there is no detailed description of possible excavation techniques (Weeks 1971: 24). Dieter Arnold offers the most comprehensive examination of stone quarrying during Pharaonic times (1991:27-40) and Denys Stocks has addressed the use of copper and bronze chisels for stone cutting (2003:25-33). But again the precise excavation systems employed at the face were beyond the scope of these studies.

One means of investigating the working procedures is to study the tombs and excavations themselves. The chisel marks that remain on the walls often give an indication of the sequence of working and the tools that were involved, but the most helpful features are those where the excavation process was halted before the completion of a full working cycle. In mining terms these are called 'false ends'.

The Cow Catacombs have a couple of false ends where the original working plan was abandoned and the excavation

work was halted in mid cycle so that the face was not cleaned off to remove the evidence of the initial intention. The excavation of the later stages of the Cow Catacombs seems to have been fairly rough and portions have therefore been left in an unfinished state. These features bring us very close to the original workmen because it is possible to detect the last chisel cut they made and to model their last working position when work ceased over two thousand years ago.

### Excavation Strategy

Before considering the evidence from these features it is necessary to consider the overall strategy of the excavation. A number of factors are likely to have determined the location and plan for the excavation of the Cow Catacombs. While there were considerations such as the proximity of the temples and the normal design for underground chambers apparent in the Serapeum, there was also the competence and hardness of the rock strata and the existence of earlier tombs.

The area in which the catacombs are located is honeycombed with previous tomb excavations, and indeed it was the clearing of an Old Kingdom tomb that led to the modern discovery of the Sacred Animal Necropolis. Old Kingdom tomb chambers occur near the surface and are also found at greater depth. The tomb diggers may have known about the location of these prior workings before commencing the catacombs because the Cow Catacombs were driven from the rock face of the Abu Sir-Serapeum Valley conveniently positioned just under the upper tombs and above the lower ones.

The knowledge of these tombs would certainly have been



**Figure 2:** A general view of the false end. There is a modern buttress built under the bench in the middle of the Main Passage to support the bench.

**Figure 3:** Front elevation, plan and section of the bench showing the chisel marks.

obtained during the excavation of the catacombs. The upper tombs are about 30 cm above the roof of the Cow Catacombs and as they were only partially filled with sand, would not have posed an immediate major threat to the workmen.

The large area of collapsed roof at present in the catacombs is the result of the collapse of an upper tomb chamber floor (Figure 1). This was precipitated by the failure of the pillar between two long catacombs that was made too narrow possibly as the result of a surveying error by the workmen. The fall probably occurred at the end of the catacombs life after it ceased to be used as the burial place for the mothers of Apis.

The Old Kingdom tomb shafts sunk to the lower chambers were more of a nuisance and presented a greater threat to the workers. These shafts were filled with sand that could burst forth burying the workman if they were encountered during excavation work. Dry sand under pressure can flow like water and is treacherous because it silently engulfs all in its path preventing escape. The shafts were dealt with by either removing the sand from them and walling them off, or by redirecting the excavation of the catacombs to avoid them. In any event, the effect of the various existing excavations around the Cow Catacombs was predominantly short term rather than of major strategic importance. The extent of the problem is evident from the fact that the rear of the catacombs is almost full of sand that came from these shafts.

The competence and hardness of the various strata however appear to have been of primary importance. The rock in which the catacombs were excavated comprises horizontal beds of limestone varying in thickness from 10cm to 1m. Each layer differs in hardness and strength from the one above and below so that by careful management it was possible to excavate in soft material and leave a harder stratum to form the roof.

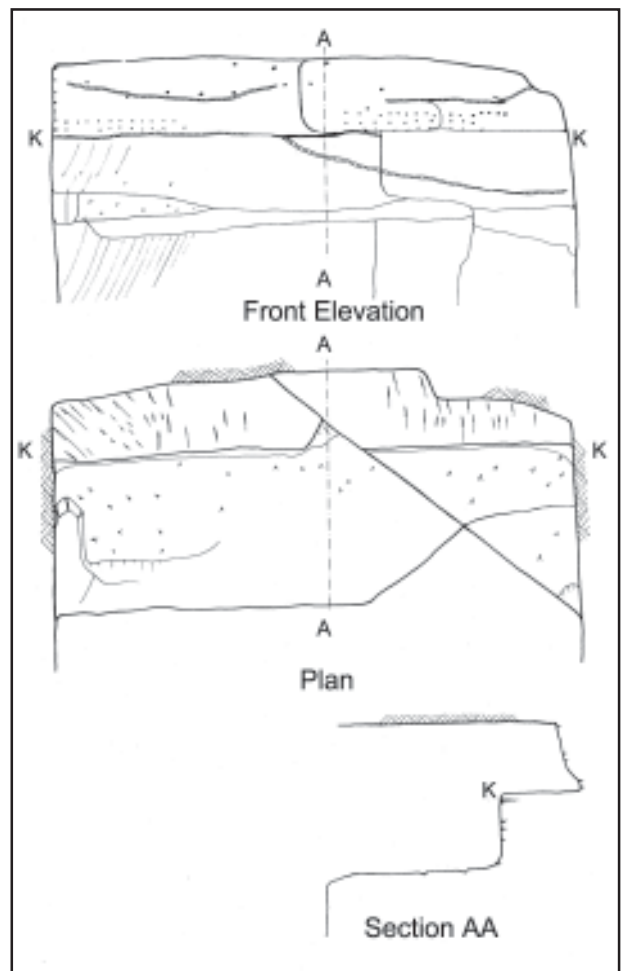

The rock also has discontinuities: veins of calcite up to 1cm thick occur in the limestone providing a surface that could assist the excavators. Horizontal veins were utilized by the workmen in the excavation sequence but the numerous vertical discontinuities, which occur with random direction, were of limited assistance. These fractures in the

rock greatly reduce its overall strength and its capacity to remain stable around large openings.

The roof of the Cow Catacombs consists of a fairly hard limestone stratum that provides a strong and safe roof. However, the upper two metres of the catacomb walls at the entrance also consist of hard or medium-hard limestone and softer strata only occur near the floor. It might have been expected that the excavators would have chosen a lower roof level in these circumstances, which indeed they did at the rear of the Cow Catacombs.

Thirty-five meters from the entrance, the roof level was lowered by 2.3 m and it is this change which left the false end. The new roof is still formed by a stratum of hard limestone, but the strata to be removed was soft and easily excavated. The strata excavated in the rear part of the Cow Catacombs coincide precisely with those of the Lower Baboon Catacombs and is a little higher than those of the Falcon Catacombs. The workmen would have no doubt been familiar with the stratigraphic sequence of Limestone but still chose to start the excavation of the Cow Galleries in comparatively hard material. A reason for this is not immediately obvious, but may possibly be deduced from the study of the excavation technique discussed below. Only four more burial chambers were cut after this decision and these have not been cleared of sand.

While excavating the catacombs to a predetermined plan, it is noteworthy that the workmen were still able to use the properties of the rock to their advantage. In particular the randomly occurring veins in the calcite were used wherever possible to assist with the breaking of the stone.

### Excavation of the Main Passage

The main passageway of the Cow Catacombs was about 4m wide, 4-5m high and was rectangular in section. It is probable that the main passage was only extended each time there was the need for additional burial chambers. The burial chambers are 3-4m wide and have arched roofs in contrast to the flat roof of the main passageway.

The decision to lower the catacombs was made soon after work had begun to extend the main passage beyond burial chambers 13 and 14. In fact the false end probably represents no more than a few manshifts of work. When the decision to lower the roof was made, work immediately began at the lower level leaving the false end above (Figure 2).

An attempt has been made to reconstruct the sequence of excavation as it appears from the two benches left in the

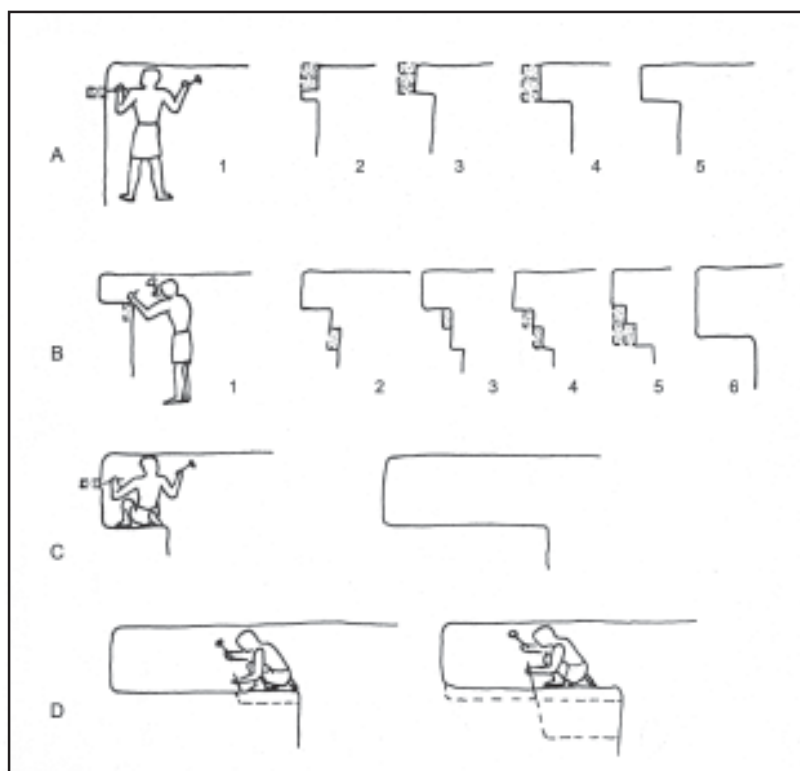

**Figure 4:** A diagram of the proposed excavation sequence for the Main Passage.

false end and also from chisel marks on the walls of the main passage. The plan, elevation and section of the benches show the chisel marks that remain visible and from which it was possible to estimate chisel sizes (Figure 3). The stages of the mining procedure are illustrated in Figure 4 and are described as follows:

#### *The first cut, A1 (Figure 4)*

A horizontal cut about 13 cm deep and 8 cm high was made across the width of the face with a chisel 25 cm long with a 5-7mm square section. A vein of calcite immediately below the cut made it easier to break the rock away. The miners were right handed and so began the cut on the left side of the face with a fan like chisel pattern similar to the 'chop cut' or 'draw cut' used occasionally in modern tunnel blasting.

A system of 'cut and easers' was used to obtain the width of the cut, each chisel cut having a burden of about 4cm (Figures 5 and 6). This system was clearly used later in the sequence for creating the groove around the bench on which the workers knelt. It is an efficient way to excavate a vertical or horizontal channel in the rock because it removed the maximum amount of stone each cut and produced a groove about 8 cm wide.

#### *Expanding the first cut, A2*

The 13 cm deep cut was extended to the roof in two stages, each approximately 15 cm high. A number of chisels were

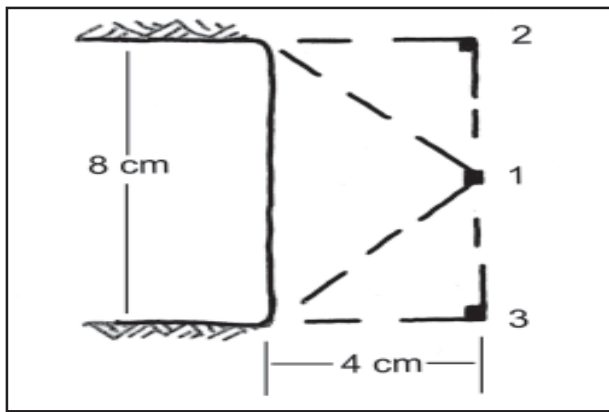

**Figure 5:** A diagram of the system of cut and easers. Chiselling follows the sequence 1,2 and 3 to advance the groove.

driven in 15 cm above the cut with a space of 10 – 20 cm between them in order to wedge a large block of limestone downward. Again a vein of calcite was exploited by the miners.

#### *Deepening the cut, A3 & A4*

The process of A1 and A2 was repeated at least a couple of times forming a bench. The bench already created would appear to make this operation difficult, but the fact that the excavation ceased when this cut was being created confirms that it was done in this way (Figure 7). The existing face also shows that process described in A2 was completed almost as far as the partially finished cut A1, indicating that steps A1 and A2 were done almost simultaneously.

#### *Removing the first bench, B*

The bench formed in A was then lowered by a series of small steps until it was 80 cm below the roof. There were

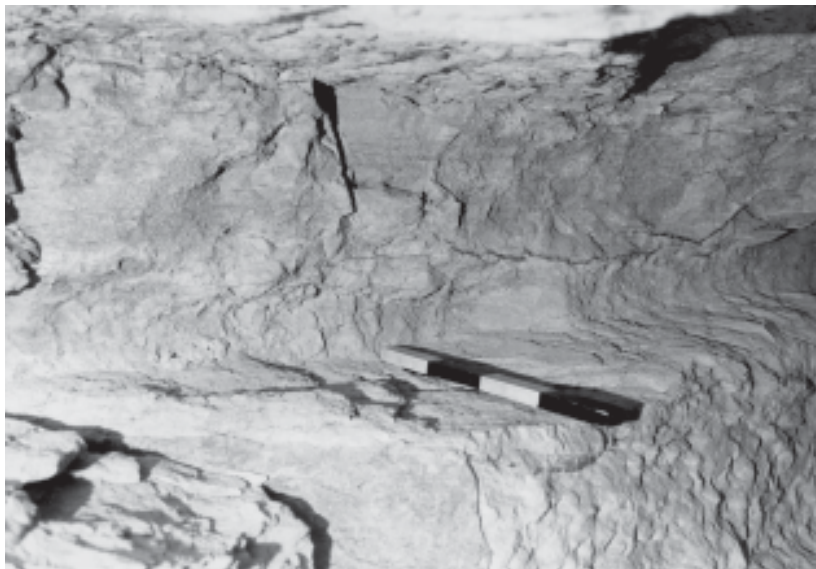

**Figure 7:** Photograph of the upper bench where work ceased. The groove being made at the rear of the bench was already being extended to the roof.

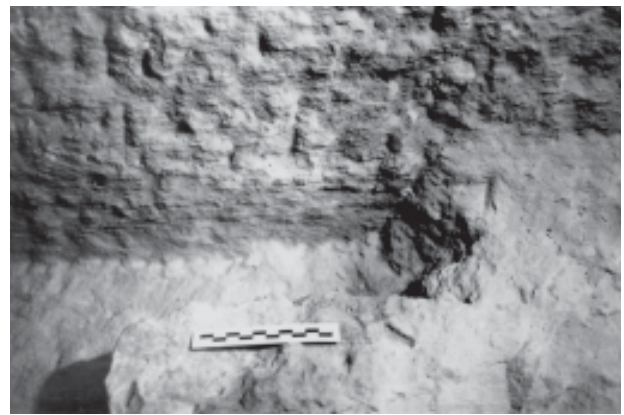

**Figure 6:** Photograph of the shallow groove on the left hand side of the main bench showing the system of cut and easers being used when work finished - position D1 Figure 4.

few clear tool marks remaining to indicate how this part of the operation was performed but it would appear that a number of chisels at a time were driven downwards about 10 cm from the face of the bench in order to prise away the stone about 10 cm wide and 20 cm deep.

#### *Advancing the heading, C*

The heading so formed had sufficient room for two men to squat and work. In this position they could continue to repeat steps A and B until an opening of sufficient length was obtained.

#### *Benching down, D*

The final operation was similar to quarrying for building stone and could have been carried on simultaneously with the driving of the top heading using as many men as space permitted. A 15 cm deep groove was cut down the left hand side of the floor of the top heading, across the bench and back along the right hand side.

The miners used a right-handed action to cut the groove and as can be seen on the left hand side to the second bench, following the system of ‘cut and easers’ as illustrated in Figure 5 but with larger chisels enabling the burden to be increased to about 6 cm and the width to 15 cm and the depth of the initial groove was probably about 10-15 cm. Tool marks on the wall indicate that the 15 cm deep groove was deepened to about 60 – 70 cm with long chisels of rectangular cross-section of 10mm x 4mm. The block of stone isolated in this fashion could then be removed using wooden wedges or levers as in a quarry operation (Lucas 1962:64). This procedure would have been repeated until the floor level was reached.

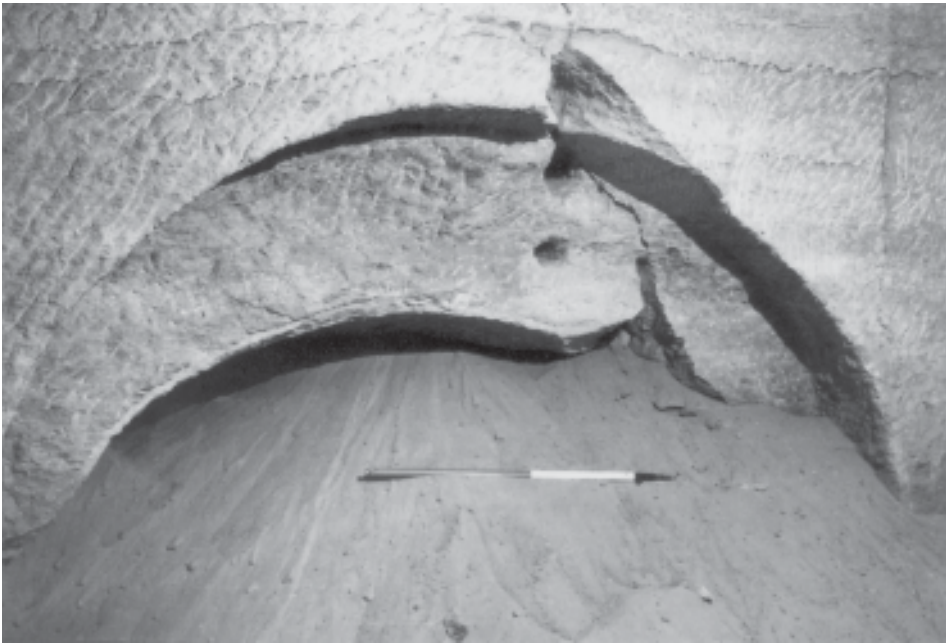

**Figure 8:** A general view of the vault of burial chamber 13 showing the two cones representing two false starts. The sand is streaming from an Old Kingdom shaft.

### Excavation of the vaulted burial chambers

The arch roof of the vaults could not be excavated in the same fashion as the flat roofed main passage. Evidence for the procedure adopted for the vaults was found immediately to the right of the place where the roof of the main passage was lowered (Figure 8). The decision to lower the roof height was made soon after the vault was begun, but not before two false starts had been made on the second end. These false starts reveal the system used in excavating the vault (Figure 9).

#### *The first cut A*

The first false start was in the form of a cone driven flush with the intended crown (centre-top) of the vault and the second was 30 cm lower. The cone was created by simultaneously driving about seven large chisels into the rock in a circular pattern of about 13 cm diameter until the chisels met about 25 cm from the face (Figures 10 and 11). Chisel marks on the roofs of other vaults indicate that the initial hole was then enlarged by successively chiselling around it until the opening was about 40 cm square (Figure 12).

**Figure 9:** A diagram of the proposed sequence of excavation for the burial chamber vaults.

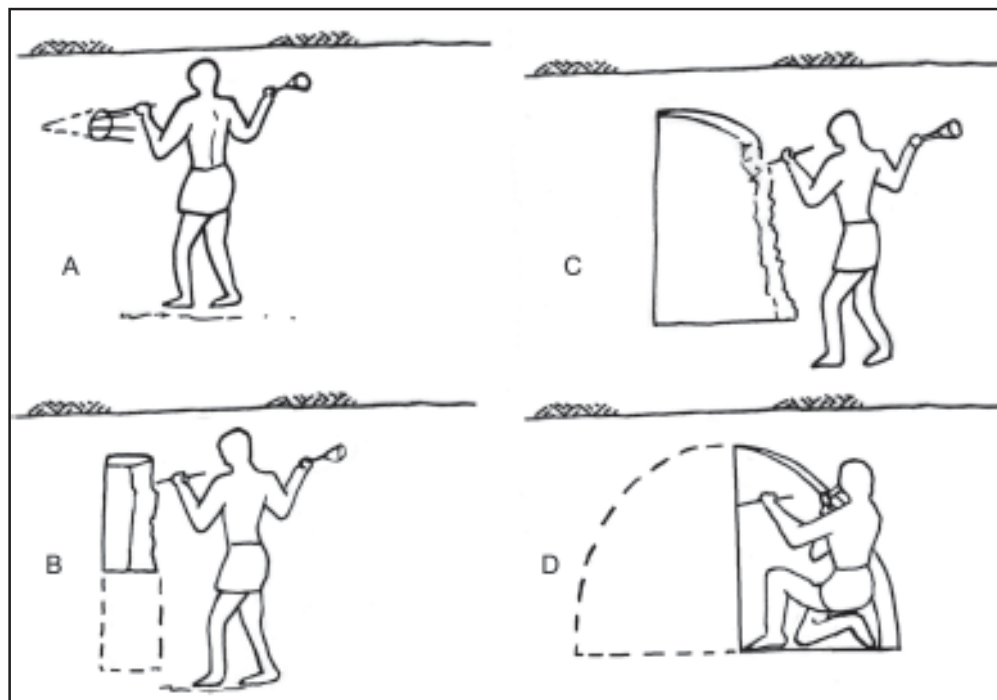

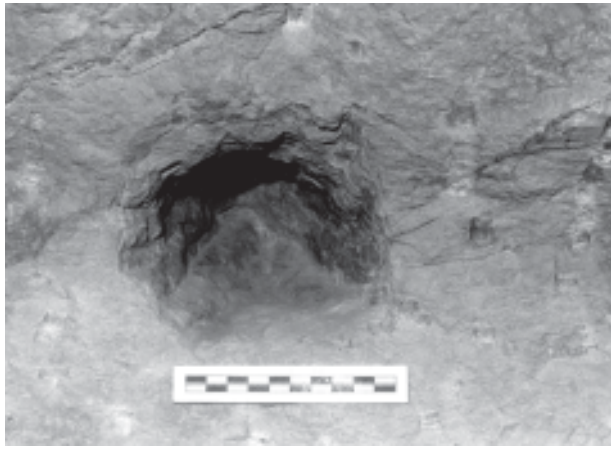

**Figure 10:** Photograph of the lower cone shown in Figure 8.

*Bench removal B*

This opening was then extended downwards to the level where the arched roof joined the walls. There is no evidence how this was accomplished, but the removal of the first bench in the Main Passage reveals one possible approach.

*Making the vault on the right side C*

The opening was extended on the right hand side following the curve of the roof until the full width of the arch on that side was attained. The right hand side of the face was removed by chiselling the face (initially the wall of the main passage) and breaking the rock into the opening already made.

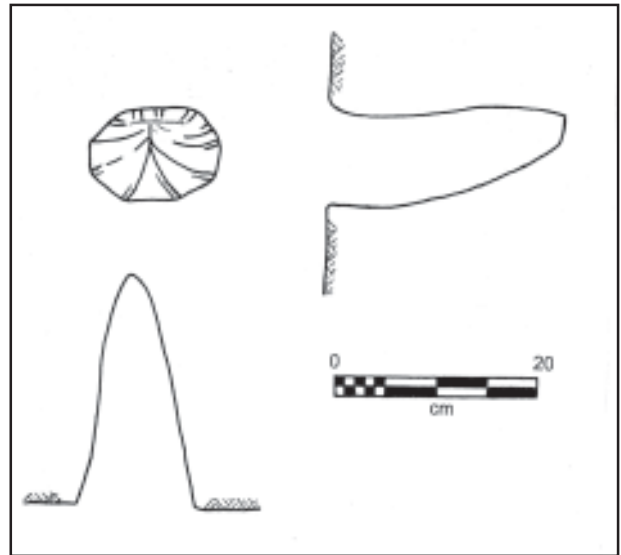

**Figure 11:** Front elevation, plan and section of the cone.

*Making the vault on the left side D*

The left side was then removed by the chiselling the left-hand side of the opening and breaking the rock outwards toward the main passage until the complete arch on the left hand side was established. The different process used to form each side of the vault is derived from the direction of the chisel marks on the vault itself. Those on the right are parallel with the direction of the vault while those on the left are at right angles to that direction (Figure 12).

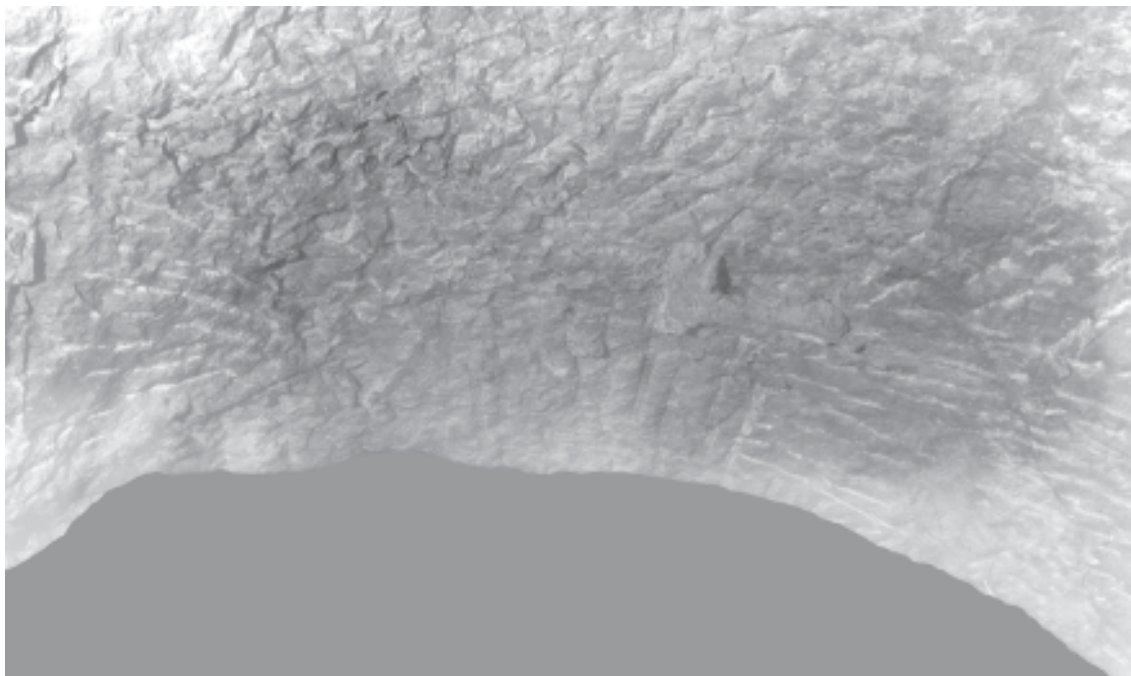

**Figure 12:** The pattern of chisel marks on the roof of a burial chamber vault. The cone was driven in the centre, and the right side in the photograph (left side of the vault) shows the chisel marks are directed away from the centre of the vault.

### *Bench Removal*

After this procedure was repeated eight or so times there was enough room for other workmen to begin benching downward to floor level as was done in the main passage. About three men could have been employed cutting the top-heading, that is making the arched roof and when space permitted, a similar number could have worked on lowering the bench. The excavation of the bench down to floor level would have been accomplished by means of grooves and wedges as it was in the main passage.

### **Excavating systems**

The system of driving a top-heading and removing the remaining bench with downward holes for explosives is often used in modern tunnelling and is common in many large underground excavations such as hydro-electric stations. The advantages of this system are:

- the roof is made clean, safe and secure at the beginning so that subsequent operations do not have to contend with dangerous rock conditions overhead,
- the work of cleaning and securing the roof can be done without the use of scaffolding or other forms of support. For workers using candlelight the immediate proximity of the working surface was important.
- the excavation is immediately made according to plan and has the outline of the opening defined for the benefit of subsequent work,
- the excavation of the top-heading may be carried out independently of the removal of the main bench. Thus short delays in one operation will not immediately affect the other, and
- the working area is large providing adequate space for numerous miners and progress is therefore faster.

The adoption of this system by the excavators of the Cow Catacombs made it possible to remove the bench by means of groove and wedging which itself has added advantages in that it:

- prevented overbreak and produced clean walls in a fashion similar to modern 'pre-split' blasting,
- resulted in large blocks of stone suitable for building purposes,
- is efficient mining as there is a minimum of rock hewing required thereby reducing the amount of chisel sharpening necessary and
- is also efficient as mucking, that is removal of the excavated material, in a pre-machine age is made quicker by dragging a block of stone away rather

than collecting many fragments of abrasive stone in baskets.

The method of driving a top heading and then benching down was well established in Egyptian tomb excavation by the end of the New Kingdom. The author has observed that the last room in the Tomb of Horemheb, in the Valley of the Kings, is unfinished and that it has its upper section only excavated. The reason for the use of this system in the Valley of the Kings is probably related to the poorer quality of the limestone and the need to get the lengthy decorating activity under way. By completing the roof first it could be made clean and secure and probably decorated before the lower sections of the room were removed.

The reason for the adoption of the system at Saqqara in the Cow Catacombs is probably rather different. The Cow Catacombs are next to the temple complex that required building stone from time to time. The production of building stone was probably a major reason for the Cow Catacombs being excavated in harder limestone and for the application of the system described above. When such stone was no longer required, the excavation could be lowered into softer limestone that would disintegrate during excavation rather than form blocks. It is also possible that it was necessary to have the vaults formed in the more competent limestone.

Two different methods were used for making the crucial initial opening in the face. In the main passage a fan-like system of chisel cuts was used starting from the left hand side and working to the right, progressively straightening up so that by the time the middle of the passage was reached the chiselling was in line with the passage. This is similar to the modern equivalent that is called a 'drag' or 'draw' cut and is generally used in softer strata (Lewis 1964: 165). Good miners are able to adjust the drilling of the face to make use of any discontinuities in the rock. In the same way the workmen in the Cow Catacombs were able to use the bands of calcite.

The vaults were excavated by a second method involving the application of a cone. This is similar to the most common method used today in tunnelling where a hole known as a 'burn cut' is made initially in the face (Lewis 1964:167). The use of cones has been noted in mining at Timna dating from the New Kingdom although it seems these were not made by a number of chisels driven simultaneously (Conrad 1980:83). The use of cones to make the first opening in a face does not appear to be common in tomb excavation in Egypt.

The unfinished tomb of Ramose in the Valley of the Nobles, for example, has an unfinished face which was being excavated by means of a groove around the entire perimeter of the passage. The rock isolated by the groove then appeared to be removed by picking in a fashion akin to that used in the Roman Catacombs, where picks were generally used.

## Chisels

The workmen in the Cow Catacombs used mallet and chisel and there is no evidence for the use of picks, although there is a possibility that some of the walls in the softer limestone were partially dressed with the use of an adze. Chisels are the only practical way to excavate harder limestone. Picks rely on strong hafting, something that was hard to achieve in ancient times, and they also would be inclined to rebound when striking harder stone. Accuracy of the cut was important and this could only be achieved with the application of chisels.

The chisels used for making the cones had a blade width of about 10mm. These chisels were up to 30 cm long and appear to have had a flat rectangular cross-section. The cone openings were slightly concave revealing that the chisels flexed while they were being driven.

Chisels used in all the other operations varied in length from 20 cm to 50 cm with cross-sections from 6 to 15 mm square. They were neither flat nor crosscut chisels as defined by Stocks but had points (2003:27).

This is an important aspect of the above analysis. The application of the chisel did not produce material in proportion to the size of the blade of the chisel, but according to the geometry of the excavation for which the chisel was being used. All the systems described in this paper involve the creation of an opening or groove in the face and then the breaking of rock toward the free surface so created. This technique was efficient in that it minimised the amount of chiselling and thereby, the amount of tool sharpening required.

Pointed chisels of the dimensions referred to above do not appear in the literature. Arnold states that pointed chisels made from bronze were used from New Kingdom times and he also notes that such tools are still to be found (1991:33). It is possible that the chisels used in the Cow Catacombs were made from iron. Chisels suitable for excavation in hard limestone would have been uncommon when compared to those used for the trimming of masonry and the excavating and dressing of tombs in soft limestone.

## Conclusion

The advantage for tomb excavation of the two systems used in the Cow Catacombs was that clean walls were produced immediately and much of the excavated material was suitable for building stone. Many features akin to modern tunnelling and blasting practices such as top-heading and benching sequences, pre-slitting and stripping with cut and easers were employed by the ancient miners.

All workers were right-handed, and only three basic specialities can be distinguished; benching, the work in the top-heading of the burial vault where cones were used and the work in the main passage top heading where a form of draw cut was used to make the initial opening in the face.

The benching activity was common in all quarrying work and was therefore not a specialist occupation. The work of advancing the top-headings was more specialised and more demanding as work space was limited and the chisel cuts were made horizontally. This work occupied only two or three men in each heading, while the benching operation could have employed a larger number. Only a limited number of workers in Egypt at any one time would have had the skills for excavating top headings.

The Cow Catacombs provide a window into some tunnelling techniques used in the late first millennium B.C.E. Egypt. Until more work is undertaken in Egypt's subterranean world it will not be possible to comment on the history of the techniques represented here. However it is clear that the tunnelling procedures used in the Cow Catacombs were well developed and gave a rapid advance with a minimum of effort. They had no doubt been developed from the time that copper and bronze chisels first became available in Egypt.

Christopher J. Davey  
The Australian Institute of Archaeology

## Bibliography

- Anon 1979 Millions of mummies: Archaeology and religion at North Saqqara, *Buried History* 15, no 2, 7-15.
- Arnold, Dieter 1991 *Building in Egypt: Pharaonic stone masonry*, New York: Oxford University Press.
- Conrad, Hans Günter, et al 1980 Untersuchungen zur Bergtechnik und ihre Interpretation, *Antikes Kupfer im Timna-Tal: 4000 Jahre Bergbau und Verhüttung in der Arabah (Israel)*, (eds) Hans Günter Conrad and Beno Rothenberg, Bochum, Der Anschnitt Beiheft 1, 69-94.
- Davey, Christopher J. 1980 Die Begräbnisstätte der heiligen Tiere in Nord-Saqqara (Ägypten), *Der Anschnitt*, 32, nos 5-6, 228-234.
- Emery, W.B. 1971 Preliminary report on the excavations at North Saqqara, *JEA*, 57, 3-13.
- Flinders Petrie, Sir W.M. 1917 *Tools and Weapons*, Warminster: Aris & Phillips.
- Green, Christine I. 1987 *The temple furniture from the Sacred Animal Necropolis at North Saqqara 1964-1976*, Fifty-third Excavation Memoir, London: Egypt Exploration Society.

- Lewis, Robert S. 1964 *Elements of Mining*, 3<sup>rd</sup> ed, New York: John Wiley.
- Lucas, A. 1962 *Ancient Egyptian Materials and Industries*, 4<sup>th</sup> ed revised by J.R. Harris, London: Histories & Mysteries of Man.
- Martin, Geoffrey T. 1981 *The Sacred Animal Necropolis at North Saqqara*, Fiftieth Excavation Memoir, London: Egypt Exploration Society.
- Ray, J.D. 1978 The world of North Saqqara, *World Archaeology* 10, no 2, 149-57.
- Romer, John 1984 *Ancient Lives: The Story of the Pharaohs' tombmakers*, London: Guild Publishing.
- Smith, H.S. & D.G. Jeffreys 1978 The North Saqqara Temple-Town Survey: Preliminary Report 1976/77, *JEA*, 64 10-21.
- Stocks, Denys 2003 *Experiments in Egyptian Archaeology: Stoneworking technology in Ancient Egypt*, London: Routledge.
- Weeks, John 1971 *The Pyramids* The Cambridge introduction to the history of mankind, Cambridge: Cambridge University Press.